

## 2021 Formula SAE Japan Local Rules Number 1

Issued: February 22, 2021 (Second Edition)

The purpose of this document is to inform of the local rules that must apply to 2021 Formula SAE Japan. Any additional local rules that become necessary must be posted on the FSAEJ official website as they become available. These local rules are valid for 2021 Formula SAE Japan only.

Formula SAE Japan Rules Committee

### **J2021-1-01 Definition of First Year Vehicle (refer to Formula SAE® Rules 2021 GR.7.2.2)**

A vehicle is considered as First Year Vehicle when the team checked in at the reception of the FSAEJ event with the vehicle, not when the team registered.

### **J2021-1-02 Eligibility for Second Year Vehicle (refer to Formula SAE® Rules 2021 GR.7.3.2)**

As for EV Class, teams may use their chassis (frame and/or monocoque) built for the 2019 Formula SAE Japan event if the chassis meets or is modified to meet the applicable Formula SAE® Rules 2021.

This rule is NOT applied to ICV Class.

### **J2021-1-03 Submission of Structural Equivalency Sheet (refer to Formula SAE® Rules 2021 DR.3.2, F.2.1, FSAEJ2021 Participation Rules Article 14)**

In the case that the Structural Equivalency Sheet (SES) is not submitted by the deadline or the resubmission deadline instructed by the Inspection Judges, the team will be disqualified from the competition without any other penalties.

~~Resubmission of the SES must not be permitted unless specifically instructed.~~

### **J2021-1-04 Baseline Steel Material (refer to Formula SAE® Rules 2021 F.3.4.2)**

The baseline steel material must be a material that satisfies the following condition.

Mild or alloy steel with a minimum tensile strength of 290 N/mm<sup>2</sup> as guaranteed by a mechanical strength standard. The “STKM11A” is one of them.

### **J2021-1-05 Attachment Height of Impact Attenuator (refer to Formula SAE® Rules 2021 F.8.4)**

The center of the Impact Attenuator must be within 350 mm from the ground.

### **J2021-1-06 Thickness of the floor or bottom for Accumulator Container (refer to Formula SAE® Rules 2021 F.10.2.2.a)**

An aluminum sheet thickness of 3.2 mm (0.125 inches) must be accepted up to a negative tolerance of 10%.

### **J2021-1-07 Accumulator Attachment – Interpretation of Corner Attachments (refer to Formula SAE® Rules 2021 F.10.3.6.b)**

The phrase “the corner of the segment” in the Formula SAE® Rules 2021 may also be interpreted as “the corner of the container”.

**J2021-1-08 Method of Inspection for Cockpit Opening and Internal Cross Section (refer to Formula SAE® Rules 2021 T.1.1.1, T.1.2.1)**

- (1) Template **T.1.2.1** may be moved vertically within 50 mm only in order to avoid interference with the rack and pinion unit.
- (2) Template **T.1.2.1** may be split into left and right sections to enable inspection even when the rack and pinion unit is positioned on the lower frame. In other words, the slit in template **T.1.2.1** may be extended to the top and bottom sides.
- (3) Template **T.1.2.1** must be placed perpendicular to an axis formed assuming a straight line from the cockpit to the pedals and moved parallel to that axis. During this movement, template **T.1.2.1** may be rotated within  $\pm 45$  degrees around the back and forth axis.
- (4) The splined part of the steering shaft may be excluded from the inspection range of Template **T.1.1.1**.

**J2021-1-09 Driver Harness Installation (refer to Formula SAE® Rules 2021 T.2.5 - T.2.7)**

The eyebolts used to attach the driver harness must meet JIS standard B1168-1994.

The diameter of the hook part of the M10 (M8) eyebolt must satisfy 8 mm (6.3 mm).

**J2021-1-10 Relaxation of Requirement for Use of Sensors with Different Transfer Functions as Accelerator Pedal Position Sensors (APPS) (refer to Formula SAE® Rules 2021 T.4.2.2, T.4.2.3)**

Teams are not required to satisfy the rule T.4.2.3.

**J2021-1-11 JSAE Logo (refer to Formula SAE® Rules 2021 VE.1.3)**

The Society of Automotive Engineers (SAE) logo as specified in the Formula SAE® Rules must be replaced by the logo of the Society of Automotive Engineers of Japan (JSAE). In other words, teams must display the JSAE logo in a prominent location on the front and/or both sides of the vehicle. The JSAE logo stickers to be supplied to the teams at the competition site have approximate dimensions of 210 mm (width)  $\times$  115 mm (height).

**J2021-1-12 Size of Technical Inspection Stickers (refer to Formula SAE® Rules 2021 VE.1.4)**

The stickers indicating that the technical inspection has been passed are divided into the parts, with total dimensions of 150 mm (width)  $\times$  100 mm (height).

**J2021-1-13 Transponder (refer to Formula SAE® Rules 2021 VE.1.5)**

Any transponder is NOT used in 2021 Formula SAE Japan.

**J2021-1-14 Quick Jack (refer to Formula SAE® Rules 2021 VE.2.1)**

It must be possible to move the vehicle at all times using the quick jack shown in the APPENDIX J-1 without any additional manual effort. It must also be possible to utilize the quick jack without interfering with the vehicle body (i.e., the cowling, undercover, and so on).

**J2021-1-15 Fire Extinguishers (refer to Formula SAE® Rules 2021 VE.2.3)**

Teams may use fire extinguishers with NO pressure gauge. However, each fire extinguisher must be within its

expiration date and the operation lever seal must be in place. For fire extinguishers without a displayed expiration date, it must be within 5 years since the date of manufacture. For example, 3-ABC type fire extinguishers and CO<sub>2</sub> fire extinguishers are recommended.

**J2021-1-16 Driver's Equipment (refer to Formula SAE® Rules 2021 VE.3)**

The equipment in accordance with the latest standards which is equivalent or safer than Formula SAE® Rules 2021 is accepted.

**J2021-1-17 Fuel Allowed at FSAEJ (refer to Formula SAE® Rules 2021 IC.5.1.1)**

The fuel provided is only unleaded gasoline with Research Octane Number (RON) of 100.

**J2021-1-18 Fuel Supply (refer to Formula SAE® Rules 2021 IC.5.2)**

Teams may fully refuel the tank of the vehicle at the fueling station before undergoing the Technical Inspections.

**J2021-1-19 Fuel Tank and Exhaust Pipe distance (refer to Formula SAE® Rules 2021 IC.5.2.3)**

Teams must secure the clearance of the fuel tank and exhaust pipes to be no less than 50 mm.

Otherwise (if teams cannot secure a clearance of 50mm), teams must add the heat shields with fireproof equal to that of a fire wall, which prevents the temperature of the fuel from being above 50% distillate temperature of JIS standard K2202-2012 during the vehicle is running, OR the evidence of its performance are required.

**J2021-1-20 Extracting fuel from the Fuel Tank (refer to Formula SAE® Rules 2021 IC.5.3.5)**

The Fuel System must have a provision for emptying the Fuel Tank without any electric motor pump.

**J2021-1-21 Coloring of Master Switches (refer to Formula SAE® Rules 2021 IC.8.4)**

In ICV Class, the Master Switches must be red.

The cockpit-mounted switches except the Master Switch must NOT be red.

**J2021-1-22 Energy Meter Specification (refer to Formula SAE® Rules 2021 EV.4.2.1 , AD.2.2.1)**

EV teams must use the Energy Meter distributed by the Competition Organizer for the Dynamic Event.

The Specification of that, Formula Student Germany FSE2014 Energy Meter, will be on the team page.

**J2021-1-23 Scatter Shield (refer to Formula SAE® Rules 2021 T.5.3.2)**

The small gap between the Scatter Shields neighboring the hole of the motor casing is allowed. As for the hole on a vertical surface to the rotation axis, the Scatter Shield is unnecessary.

**J2021-1-24 Relaxation of the Interlocking for the Tractive System connectors outside of a housing (refer to Formula SAE® Rules 2021 EV.6.9)**

If the tractive system connector on the outside of the housing (accumulator container) cannot be removed without the use of tools by the team, we consider it to be similar to an interlock.

If so, the team must state this to the Electrical Systems Form (ESF) and obtain the approval by the judges.

**J2021-1-25 Relaxation of Prohibition of Cell Balancing when Accumulator Isolation Relays (AIR) Are Open (refer to Formula SAE® Rules 2021 EV.6.4.3, EV.8.3.2)**

Teams are not required to satisfy the rule EV.8.3.2.

**J2021-1-26 Relaxation of Rule Relating to Placement of Temperature Sensor at Cell Negative Terminal (refer to Formula SAE® Rules 2021 EV.8.5.3, EV.8.5.4)**

If the team uses a ready-made Accumulator consisting of assembled cells (segments) and built-in temperature sensor without modification, Teams are not required to satisfy the rule EV.8.5.3 and EV.8.5.4.

If so, the team must state this to the Electrical Systems Form (ESF) and obtain the approval by the judges.

**J2021-1-27 Relaxation of Requirement for Electrical Connections to Use Positive Locking Mechanisms (refer to Formula SAE® Rules 2021 EV.7.4.3)**

The requirement to use Positive Locking Mechanisms described in EV.7.4.3 must be regarded as satisfied if the following conditions are all met.

- Conditions:
- The team can clearly demonstrate that the reasonable axial force or the contact pressure has been applied to the connections during the Electrical Technical inspection. (A record of the fastening torque or riveting bonding force is acceptable.)
  - Furthermore, the structure must allow no application of external force (tension, torsional, or flexural) from the wiring to the connection.

**J2021-1-28\* Ready-To-Drive-Sound (refer to Formula SAE® Rules 2021 EV.9.4)**

Teams are not required to satisfy the rule EV.9.4.

**J2021-1-29 Coloring of Shutdown Buttons (refer to Formula SAE® Rules 2021 EV.8.11)**

EV Shutdown Buttons must be red. Other than the cockpit mounted Shutdown Button, switches installed in the cockpit must not be red nor orange.

**J2021-1-30 Relaxation of Requirement for the Overcurrent Protection in the multiple parallel battery cells (refer to Formula SAE® Rules 2021 EV.7.6.3)**

Only when the team uses ready-made segments which the multiple cells are assembled in parallel, and the Overcurrent Protection is designed on the condition that all current flows only to one side cell, teams are not required to satisfy the rule EV.7.6.3.

If so, that must be stated on the Electrical Systems Form (ESF) and approved by judges.

**J2021-1-31 Relaxation of Rules for EV Chargers (refer to Formula SAE® Rules 2021 EV.10.2.4, EV.10.4.1)**

If the team can do everything after understanding (1) to (3) below, the team is not required to satisfy ①-③.

(1) The team describes the "charging procedure" and "charging abnormality procedure" in the Electrical System Form (ESF) and obtains the approval by the judges.

(2) When the team charges, carry the Electrical System Form (ESF) with the necessary points in (1).

(3) When the team charges, it must be possible to handle the abnormality according to the "charging abnormality

procedure".

- ① Interlock function related to the connection status of the connector specified in EV.10.2.4.
- ② Function to turn off the charger by AMS specified in EV.10.4.1
- ③ Function to turn off the charger by IMD specified in EV.10.4.1

**J2021-1-32 Seals for the Rain Test (refer to Formula SAE® Rules 2021 IN.4.7.1, IN.11)**

The judges seal the vehicle in two stages.

Items 1 will be sealed before the rain test.

Items 2 will be sealed after the rain test passed.

Items 1: The items checked at the Electrical Technical Inspection (Accumulator Container(s), Motor, etc.).

Items 2: The items attached to the vehicle for waterproofing (tapes or the like).

Teams must retake the following inspection if these seals are peeled off.

Items 1: Simplified Electrical Technical Inspection for the related parts. The Rain test again in some cases.

Items 2: The Rain test again.

**J2021-1-33 Driver Egress Test (refer to Formula SAE® Rules 2021 IN.5.2)**

In the Driver Egress Test, the direction of egress (i.e., to the left or right of the vehicle) must be instructed by the judges at that time.

**J2021-1-34 Sound Measuring Procedure for CVT-Equipped Vehicles (refer to Formula SAE® Rules 2021 IN.10.1.1)**

Teams using a vehicle equipped with a CVT without a neutral position must prepare an apparatus that can safely hold the driving wheels in a completely floating state during sound measurement.

**J2021-1-35 Sound Measuring Procedure (refer to Formula SAE® Rules 2021 IN.10.1.2)**

There is no change to the measurement speed for engines used in 2019 Formula SAE Japan. The measurement speeds for other engines must be released on the team page later. The location of the microphone at an angle of 45° with the outlet in the horizontal plane must be instructed by the judges at that time.

Measuring time will be within 5 minutes from the microphone set up.

**J2021-1-36 Remeasurement of Noise (refer to Formula SAE® Rules 2021 IN10.1, IN10.6)**

- (1) The vehicle that completed the Endurance Event is subject to the noise test.
- (2) The method of the noise testing applies IN.10.1.2 and local rule J2021-1-34 correspondingly.
- (3) It calls a penalty as follows according to measurements.
  - Up to +1dB of Reference Value(RV) is NO penalty.
  - Over +1dB up to +2dB of RV is a penalty of 10 points.
  - Over +2dB of RV is a penalty of 20 points.

**J2021-1-37 Technical Inspection After the Endurance (refer to Formula SAE® Rules 2021 IN.15.3.2, D.14.1)**

The vehicles may be re-inspected after the Endurance and refueling are completed.

**J2021-1-38\* Relaxation of feedback control of Intermediate Circuit(refer to Formula SAE® Rules 2021 EV.6.6.2)**

Teams are not required to satisfy the rule EV.6.6.2.

**J2021-1-39\* Relaxing Positive Temperature Coefficient (PTC) devices usage(refer to Formula SAE® Rules 2021 EV.6.6.5)**

Teams are not required to satisfy the rule EV.6.6.5.

**J2021-1-40\* Relaxation of precharge relay(refer to Formula SAE® Rules 2021 EV.6.6.6)**

Teams are not required to satisfy the rule EV.6.6.6.

**J2021-1-41\* Relaxation of monitoring targets by AMS(refer to Formula SAE® Rules 2021 EV.8.3.3)**

Teams are not required to satisfy the rule EV.8.3.3 b, d, e.

**J2021-1-42\* Relaxation of BSPD inspection methods(refer to Formula SAE® Rules 2021 EV.8.7.5)**

Teams are not required to satisfy the rule EV.8.7.5 a, b.

**J2021-1-43 Relaxation of insulation distance when integrated circuits are used such as opto-couplers (refer to Formula SAE® Rules 2021 EV.7.5.7)**

Even if integrated circuits are used such as opto-couplers which are rated for the respective maximum tractive system voltage but do not fulfill the required spacing, they may still be used and the given spacing does not apply.

**J2021-1-44 Spare Accumulators (refer to Formula SAE® Rules 2021 EV.6.1.4)**

If spare Accumulators are to be used, they all must be of the same size, weight and type as those that are replaced.

**\* These rules are made for the vehicles compatible with Formula SAE® Rules 2020 and will be removed in 2022 FSAEJ.**

**APPENDIX J-1 (J2021-1-13) Quick Jack**

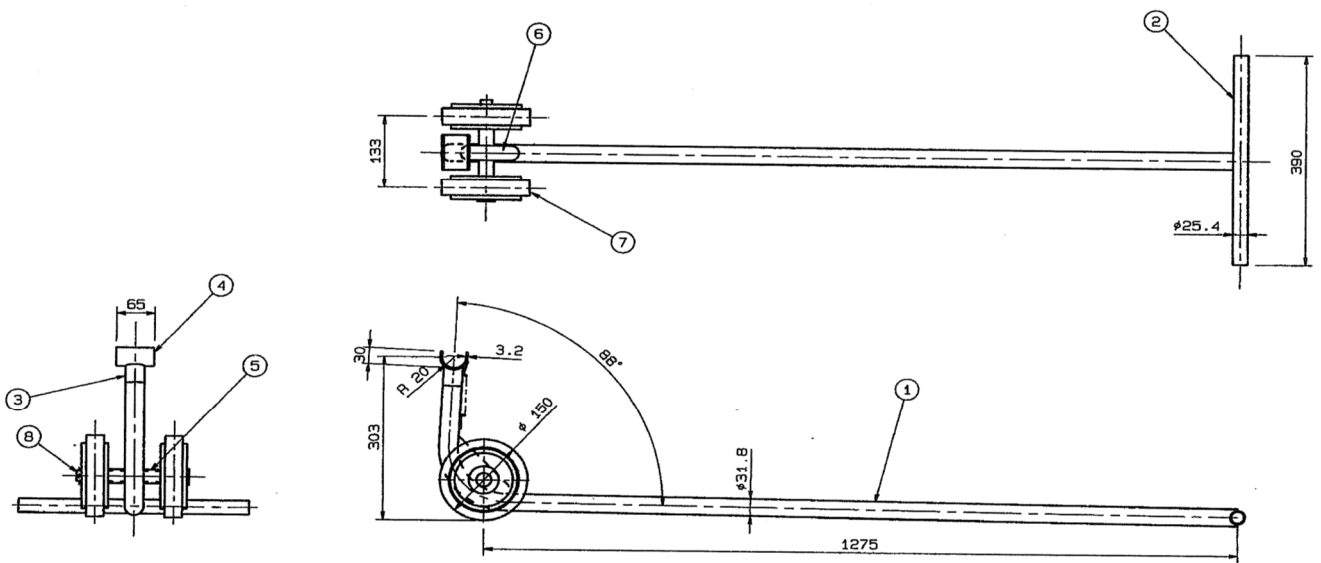

8	SHAFT	1	S45C	
7	TYRE	2		
6	GUSSET	1	SPCC t1.6	
5	HOUSING	1	SPCC t2.3	
4	SUPPORT	1	SPCC t3.2	
3	NECK	1	SS400	
2	HANDLE	1	SINW25.4t1.6	
1	MAIN TUBE	1	SINW31.8t1.6	
	QUICK LIFT JACK	1		
NO	PART NO	NAME	QTY	MATERIAL



**Revision Record:**

**[Second Edition]**

-J2021-1-03 Submission of Structural Equivalency Sheet

-J2021-1-09 Driver Harness Installation